

## Hi-Pergolas

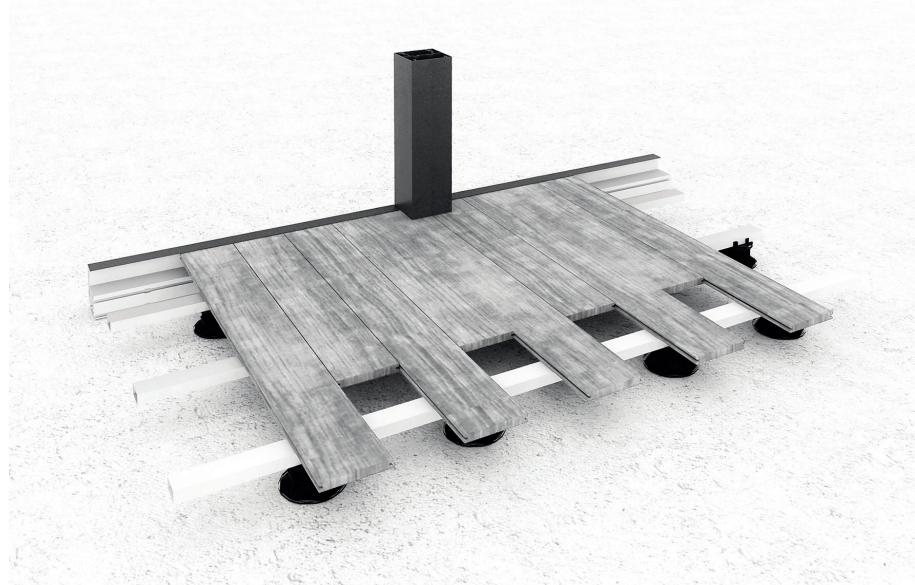

Scheda tecnica di Pre-Installazione  
 Pre-Installation technical sheet  
 Fiche technique de pre-installation  
 Vorinstallationsblatt

[Dimensioni in cm]  
 [Dimension in cm]  
 [Dimensions cm]  
 [Abmessungen in cm]

**IT** - È possibile scaricare la versione più recente di questo documento dal nostro portale B2B (effettuare una scansione del codice QR qui riportato o andare direttamente sul sito <http://b2b.pratic.it/login.jsf>). La Pratic F.Ili Orioli SpA considera questo documento come riservato e destinato al solo installatore del prodotto a cui il documento stesso è associato. La Pratic F.Ili Orioli SpA specifica, inoltre, che il presente documento viene fornito a solo scopo illustrativo ai fini del montaggio e/o della manutenzione del prodotto a cui questo documento è associato attraverso il nome commerciale del modello. Alcuni dettagli dei componenti rappresentati nel presente documento potrebbero essere diversi dalla realtà al solo scopo di tutelare la proprietà intellettuale della ditta Pratic f.Ili Orioli. È vietato qualsiasi utilizzo di questo documento a fini differenti da quelli indicati, così come la riproduzione e/o la divulgazione, anche parziale, a terzi, senza l'autorizzazione scritta specifica della Direzione della Pratic F.Ili Orioli SpA.

**EN** - You can download the latest version of this document from our B2B portal (scan the QR code here indicated or go directly to the website <http://b2b.pratic.it/login.jsf>). Pratic F.Ili Orioli Spa considers this document confidential and for the exclusive use of the installer of the product (to which the document is linked). Pratic F.Ili Orioli Spa also specifies that this document is provided for illustrative purpose only for the assembly and/or the maintenance of the product to which this document is linked by the commercial name of the model. Some details of the components represented in this document may be different from reality for the only purpose of protecting the intellectual property of the company Pratic f.Ili Orioli. Any use of this document for different purposes from those indicated is forbidden, as well as the reproduction and/or disclosure, even partial, to third parties, without the specific written authorization of Pratic F.Ili Orioli Spa management.

**FR** - On peut télécharger la dernière mise à jour de ce document depuis notre portail B2B (scannez le QR code ci-indiqué ou allez directement sur le site <http://b2b.pratic.it/login.jsf>). La société Pratic F.Ili Orioli Spa considère ce document comme confidentiel et d'utilisation exclusive de l'installateur du produit auquel le document même est lié. La Pratic F.Ili Orioli Spa spécifie aussi que ce document est fourni à seul titre d'illustration pour le montage et/ou l'entretien du produit auquel ce document est lié par le nom commercial du modèle. Certains détails des composants représentés dans ce document pourraient être différents de la réalité dans le seul but de protéger la propriété intellectuelle de la société Pratic f.Ili Orioli. Toute utilisation de ce document à des fins autres que celles indiquées est interdite, ainsi que la reproduction et/ou la divulgation, même partielle, à des tiers, sans l'autorisation spécifique par écrit de la Direction de la Pratic F.Ili Orioli Spa.

**DE** - Sie können die aktuellste Version dieses Dokuments von unserem B2B Portal herunterladen (scannen Sie den hier abgebildeten QR-Code oder gehen Sie direkt auf die Webseite <http://b2b.pratic.it/login.jsf>). Die Firma Pratic F.Ili Orioli SpA betrachtet dieses Dokument als vertraulich und es ist nur für den Installateur des Produkts bestimmt, mit dem das Dokument verbunden ist. Des Weiteren, erklärt die Firma Pratic F.Ili Orioli SpA, dass dieses Dokument nur zu Illustrationszwecken bereitgestellt wird. Zwecke in Hinblick auf die Montage bzw. Wartung des Produkts, dem dieses Dokument zugeordnet ist, über den geschäftlichen Name des Modells. Einige Details der in diesem Dokument enthaltenen Bestandteile können von der Realität abweichen, um das geistige Eigentum der Firma Pratic f.Ili Orioli zu schützen. Es ist verboten, dieses Dokument für andere als die angegebenen Zwecke zu verwenden, sowie für die teilweise Vervielfältigung bzw. Verbreitung an Dritten ohne ausdrückliche schriftliche Genehmigung der Geschäftsführung der Firma Pratic F.Ili Orioli SpA.



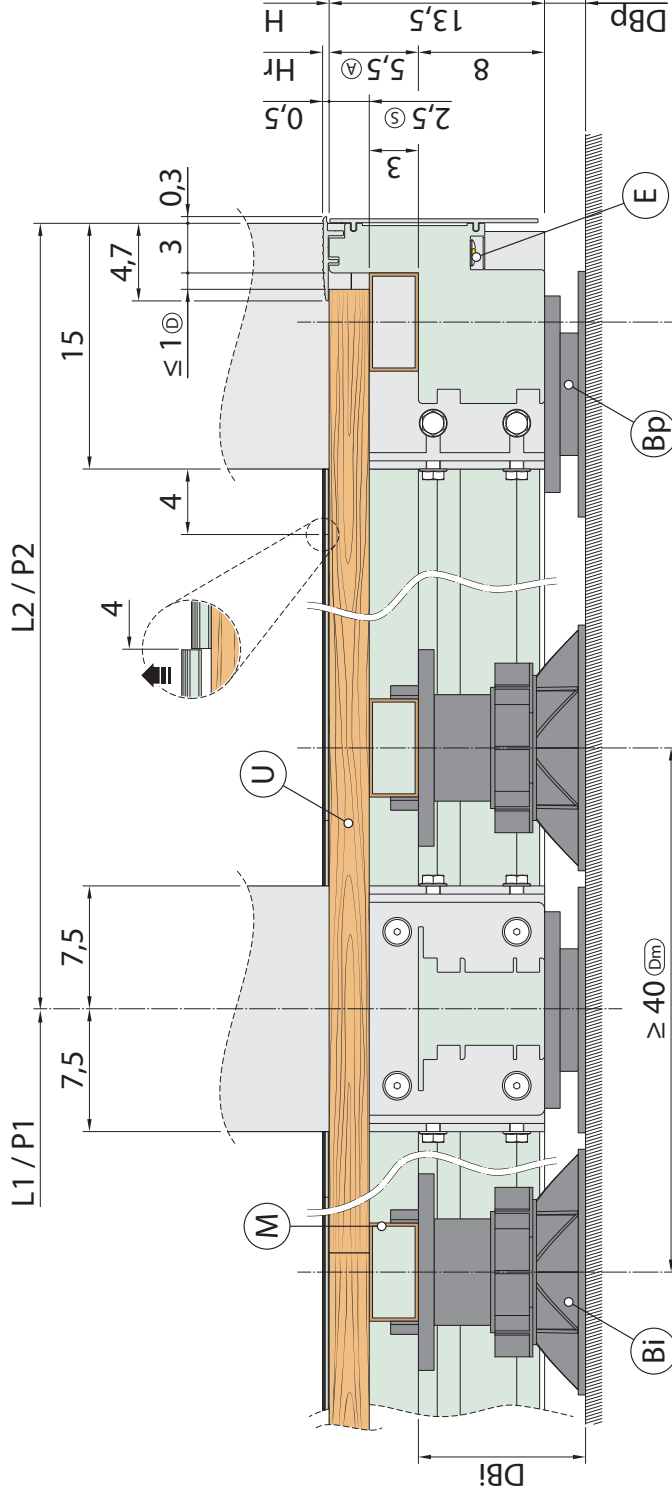

SLIDEGLASS

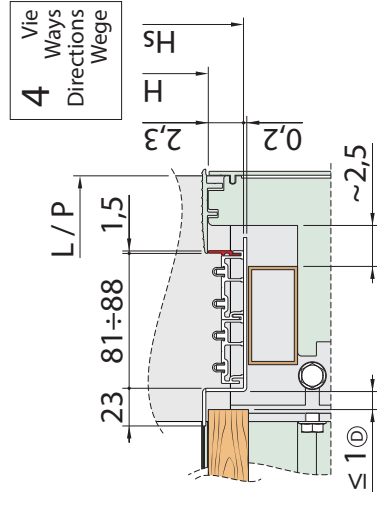
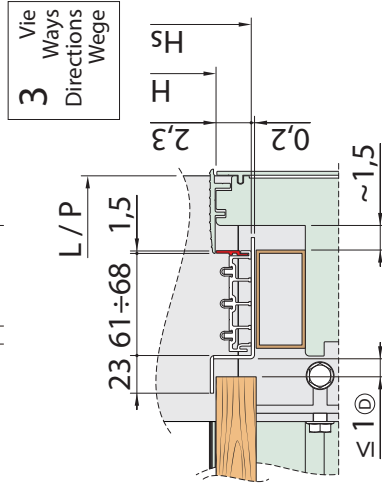
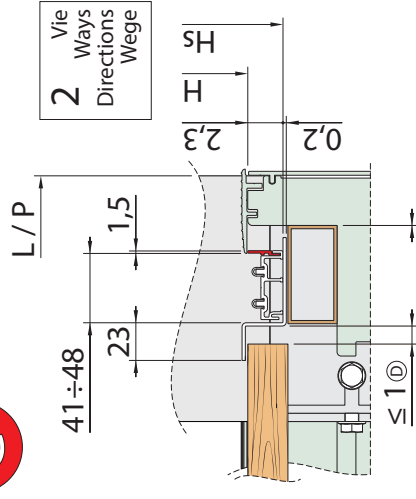

A	Spessore utile per allestimento	Useful thickness for setting up	Epaisseur utile pour l'équipement	Nützliche Dicke zur Ausrichtung
<b>Bi</b>	Supporto interno	Internal support	Support intérieur	Stelzlager
<b>Bp</b>	Supporto perimetrale	Perimeter support	Support périphérique	Umlaufendes Stelzlager
<b>Dbi</b>	Range regolazione supporto <b>Bi</b>	<b>Bi</b> support adjustment range	Portée régulation support <b>Bi</b>	Stelzlager <b>Bi</b> Justierung Reichweite
<b>DBp</b>	Range regolazione supporto <b>Bp</b>	<b>Bp</b> support adjustment range	Portée régulation support <b>Bp</b>	Stelzlager <b>Bp</b> Justierung Reichweite
<b>Dm *</b>	Interasse magatelli	Joist interaxle spacing	Entraxe lambourdes	Balken Achsabstand
<b>D *</b>	Spazio utile per dilatazione pavimento	Useful space for floor expansion	Espace utile pour la dilatation de sol	Nutzfläche zur Bodenerweiterung
<b>E</b>	LED perimetrali integrati	Built-in perimeter LEDs	Ingrès LED sur le périmètre	Umlaufende integrierte LEDs
<b>H</b>	Altezza HI-Pergolas	HI-Pergolas height	Hauteur HI-Pergolas	HI-Pergolas Höhe
<b>Hr</b>	Altezza Raso	Raso height	Hauteur Raso	Raso Höhe
<b>Hs</b>	Altezza Slide Glass ( <b>H + 2,3</b> )	Slide Glass height ( <b>H + 2,3</b> )	Hauteur Slide Glass ( <b>H + 2,3</b> )	Slide Glass Höhe ( <b>H + 2,3</b> )
<b>M</b>	Magatello ( <b>6 x 3</b> )	Joist ( <b>6 x 3</b> )	Lambourde ( <b>6 x 3</b> )	Balken ( <b>6 x 3</b> )
<b>S *</b>	Spessore utile per pavimentazione	Useful thickness for pavement	Epaisseur utile pour le revêtement	Nützliche Dicke für den Bodenbelag
<b>U *</b>	Pavimentazione	Pavement	Revêtement	Bodenbelag
<b>(*)</b>	Consultare la documentazione del fornitore	Please refer to the supplier documentation	Consulter la documentation du fournisseur	Schauen Sie in den Unterlagen des Lieferanten nach

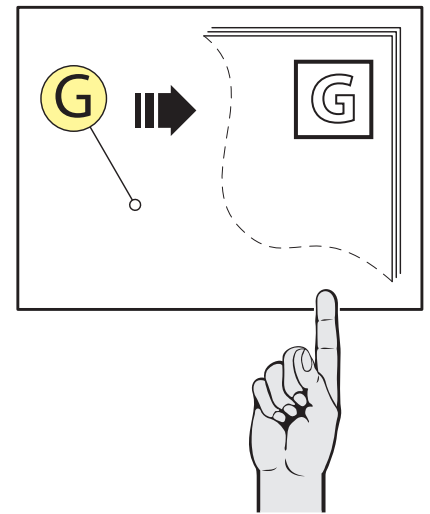
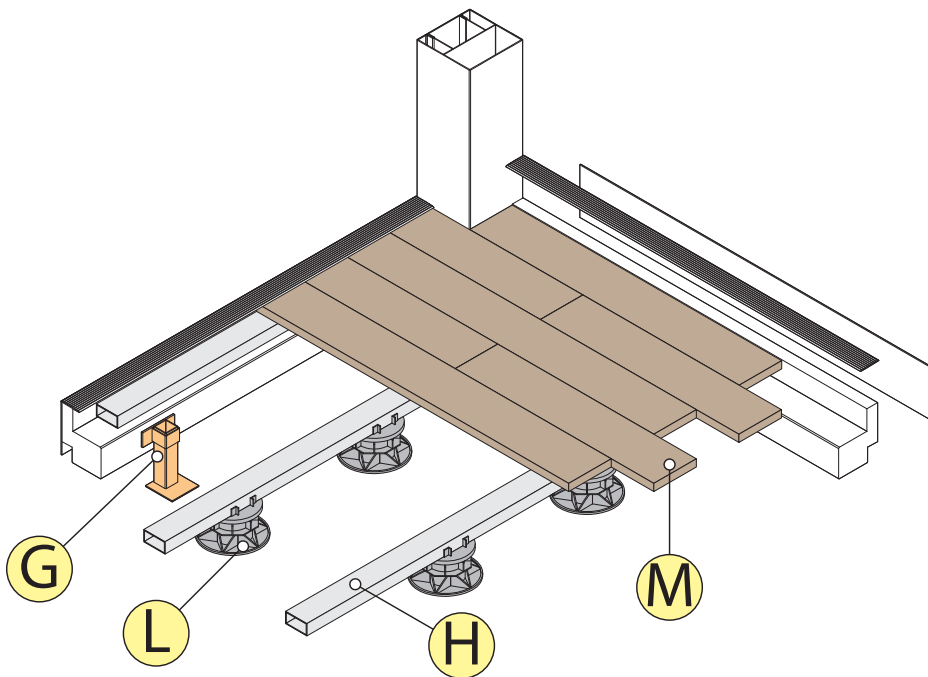

Per il corretto fissaggio è possibile utilizzare la dima di installazione allegata.

For a proper installation, the attached installation template is also available.

Pour la correcte installation vous pouvez aussi utiliser la silhouette d'installation annexé.

Zur korrekten Befestigung ist es möglich, auch die beiliegende Montageschablone zu verwenden.

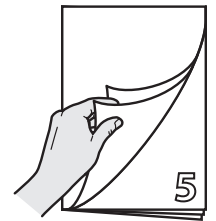

**SISTEMI DI ANCORAGGIO:** È responsabilità dell'installatore la corretta scelta dei sistemi di ancoraggio idonei al tipo di supporto su cui ancorarsi e dei carichi derivanti dal peso della struttura e dall'azione del vento. (\*\*\*) Immagini puramente indicative).

Per applicazioni di prodotti Pratic su supporti/strutture preesistenti è responsabilità dell'installatore garantire l'adeguatezza strutturale del supporto/struttura preesistente.

**ANCHORING SYSTEMS:** It is responsibility of the fitter to correctly choose the anchoring systems suitable to the type of support on which it is necessary to anchor and the loads due to the weight of the structure and the wind action. (\*\*\*) Images shown are indicative only)

To install Pratic products on existing supports/structures it is responsibility of the installer to guarantee the structural adequacy of the existing support/structure.

**SYSTÈMES D'ANCRAGE:** L'installateur est responsable de la bonne choix des systèmes d'ancrage appropriés au type de support sur lequel s'ancrer et des charges résultants du poids de la structure et de l'action du vent (\*\*\*) Les photos sont à titre purement indicatif).

Pour applications de produits Pratic sur supports/structures préexistantes, l'installateur a la responsabilité de garantir l'adéquation structurale du support/structure préexistante.

**VERANKERUNGSSYSTEME:** Der Installateur ist dafür verantwortlich, die richtigen, für die Art der zu ankernden Unterlage geeigneten Verankerungssysteme anzuwählen, als auch die von dem Gewicht der Struktur und der Wirkung des Windes verursachten Lasten.

(\*\*\*) Die gezeigten Bilder dienen nur als Referenz). Für Anwendungen von Produkten von Pratic auf Trägern/bereits existierenden Strukturen liegt die Verantwortung beim Installateur, die strukturelle Angemessenheit des Trägers/der bereits existierenden Struktur zu garantieren.

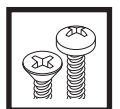

\*\*\*

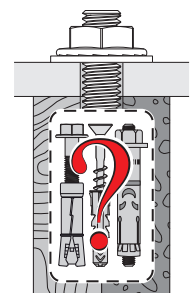



## Pergola + Raso

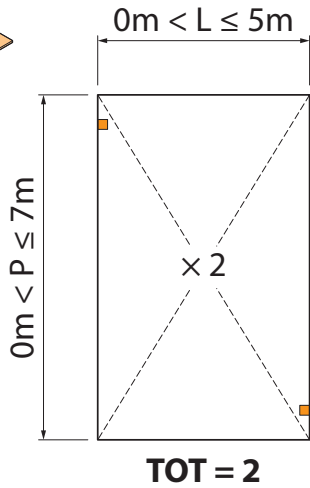
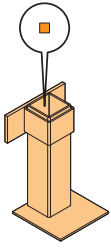

## Pergola + Raso + SlideGlass



Scala Scale Échelle Skala	Grado Degree Degré Grad	Grado Degree Degré Grad		Grado Degree Degré Grad			Grado Degree Degré Grad
Beaufort	11	10		9			8
Profondità / Depth / Profondeur / Tiefe	200	2L × 2P	2L × 2P	2L × 2P	3L × 2P	3L × 2P	3L × 2P
	250	2L × 2P	2L × 2P	2L × 2P	2L × 2P	3L × 2P	3L × 2P
	300	2L × 2P	2L × 2P	2L × 2P	2L × 2P	3L × 2P	3L × 2P
	350	2L × 3P	2L × 2P	2L × 2P	2L × 2P	2L × 2P	3L × 2P
	400	2L × 3P	2L × 3P	2L × 3P	2L × 2P	2L × 2P	3L × 2P
	450	2L × 3P	2L × 3P	2L × 3P	2L × 3P	2L × 3P	2L × 2P
	500	2L × 3P	2L × 3P	2L × 3P	2L × 3P	2L × 3P	2L × 2P
	550	2L × 3P	2L × 3P	2L × 3P	2L × 3P	2L × 3P	2L × 3P
	600	2L × 3P	2L × 3P	2L × 3P	2L × 3P	2L × 3P	2L × 3P
	650	2L × 3P	2L × 3P	2L × 3P	2L × 3P	2L × 3P	2L × 3P
700	2L × 3P	2L × 3P	2L × 3P	2L × 3P	2L × 3P	2L × 3P	
nL × nP	200	250	300	350	400	450	500
Larghezza / Width / Largeur / Breite							

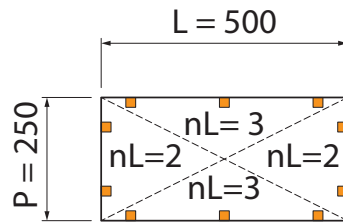
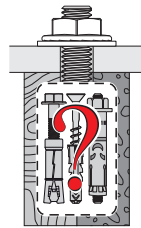
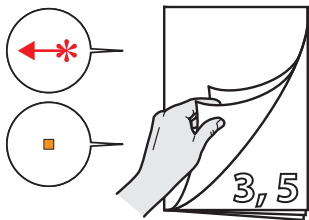

Esempio: Pedana 500 × 250  
 Example: Platform 500 × 250  
 Exemple: Plate-forme 500 × 250  
 Beispiel: Unterbau 500 × 250

**TOT = 2xnL + 2xnP = 10**

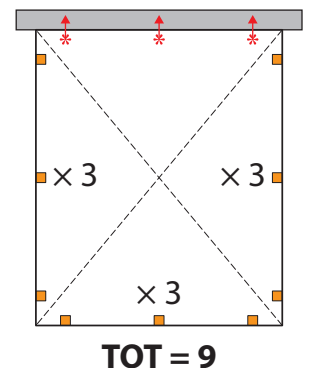
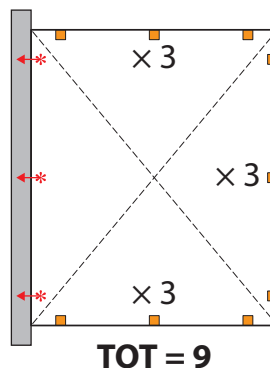
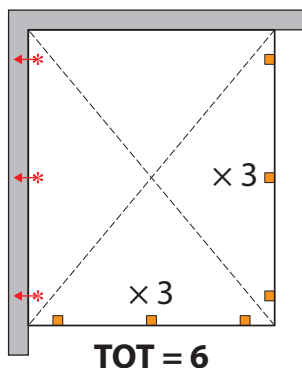
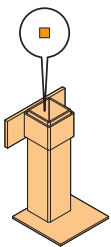
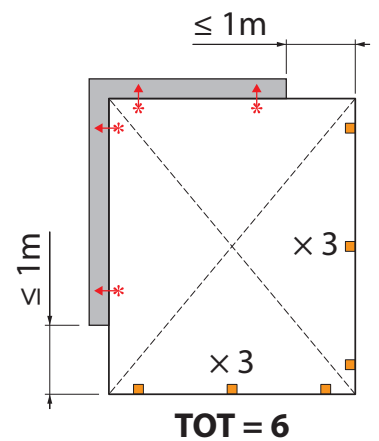
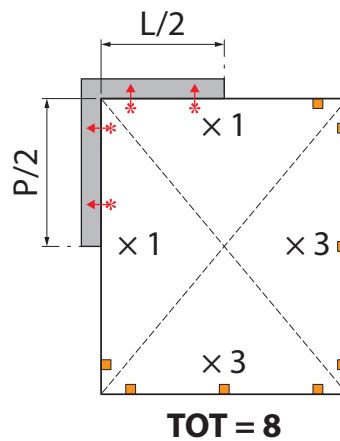
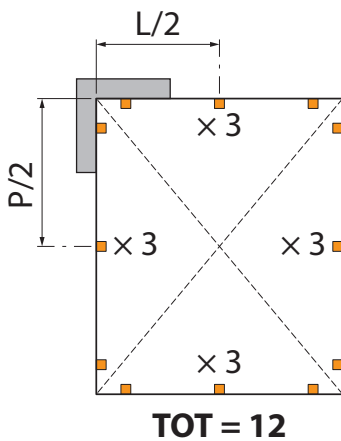

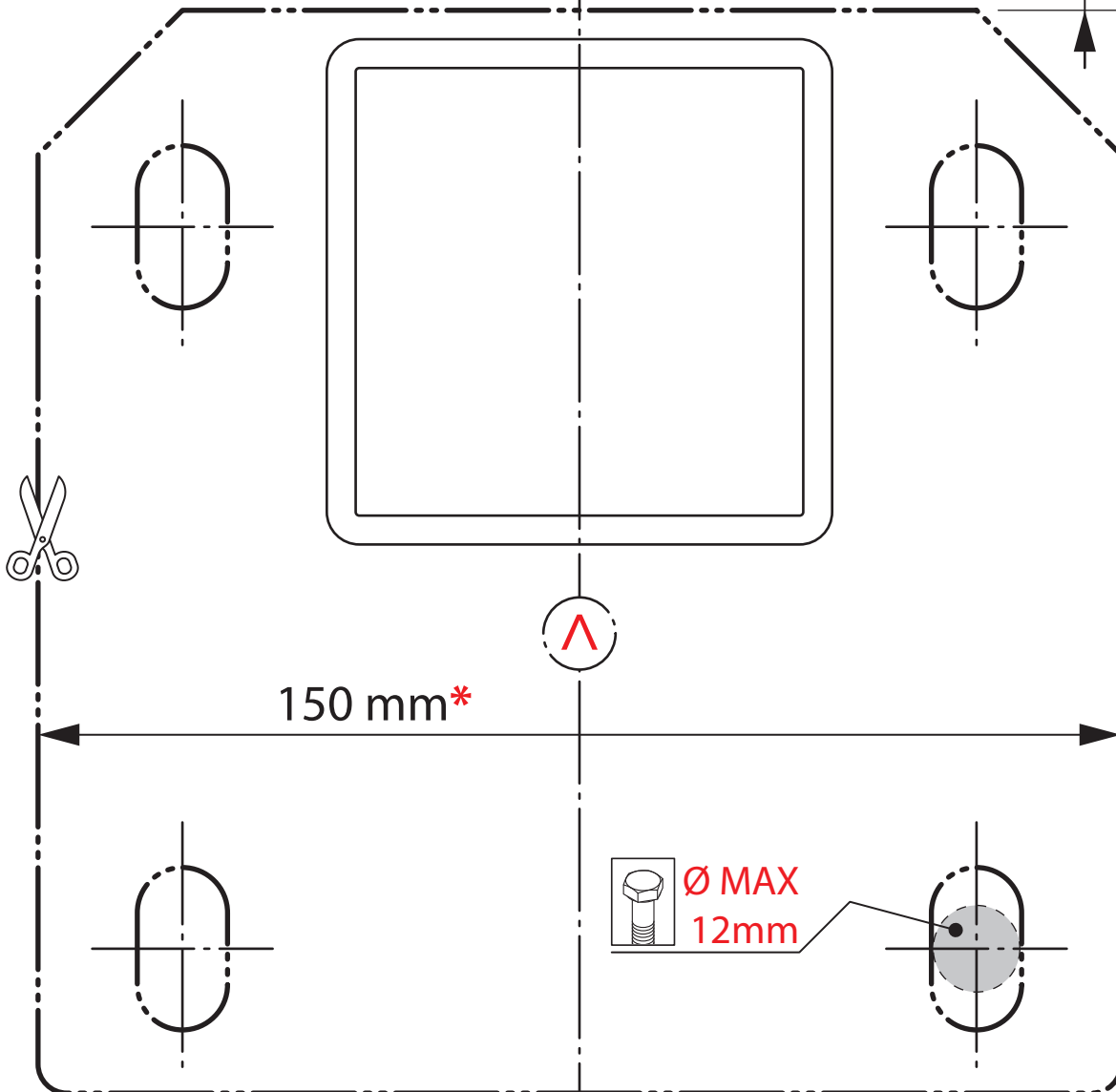
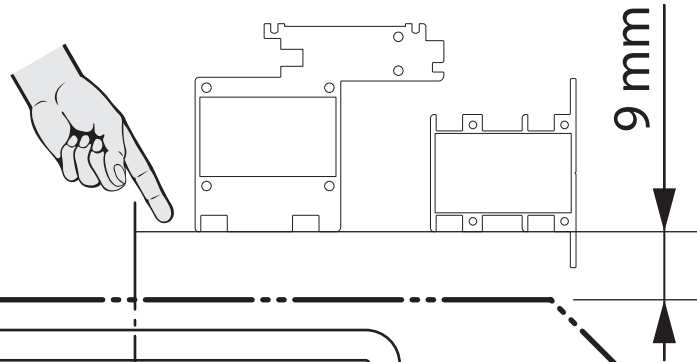
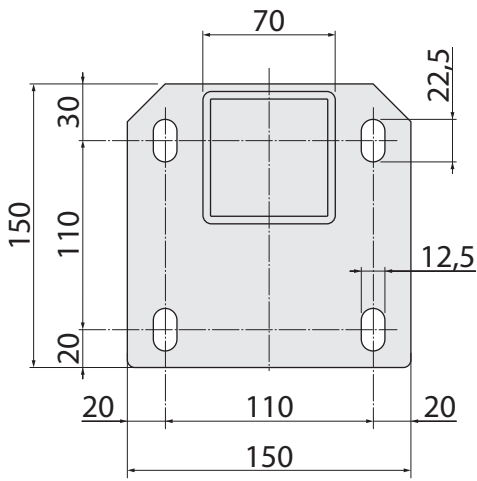

7405

(Dimensioni di ingombro in mm) Verificare la quota \* prima di utilizzare il presente disegno  
 (Overall dimension in mm) Please verify the measure \* before using this drawing  
 (Dimensions d'encombrement en mm) Vérifiez la mesure \* avant d'utiliser ce dessin  
 (Außenabmessungen in mm) Bevor der Verwend.dieser Zeichnung, überprüfen Sie das Maß \*

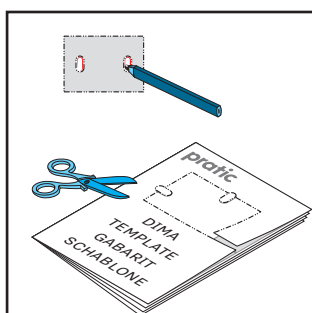

Questa pagina è stata lasciata volutamente vuota per consentire il taglio e l'utilizzo della dima stampata sul retro.

This page has been intentionally left blank to allow the cutting and the use of the template printed on the back.

Cette page a été laissée blanche intentionnellement pour permettre la coupe et l'utilisation du gabarit imprimé sur le dos.

Diese Seite wurde absichtlich leer gelassen, um den Schnitt und die Verwendung der auf der Rückseite gedruckten Schablone zu ermöglichen.

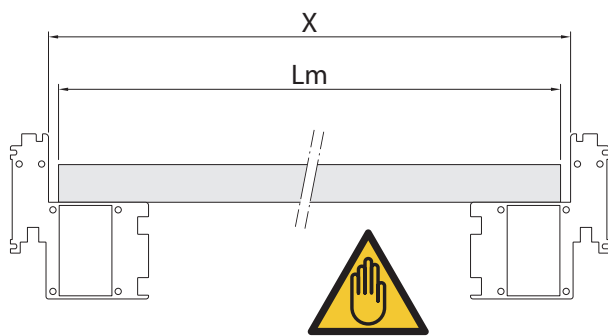
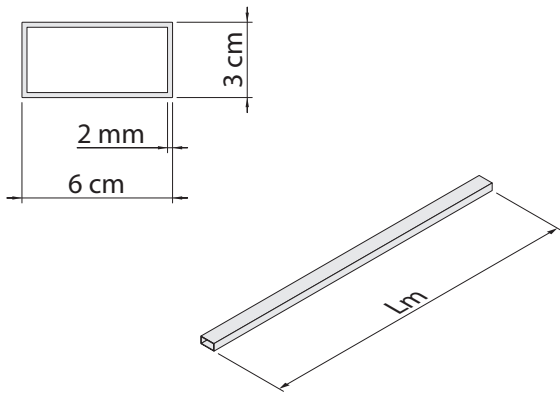

$$X - Lm \leq 5mm$$

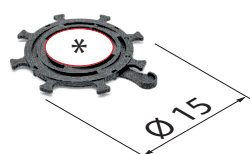

PU (P)

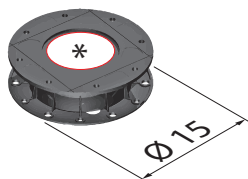

MN (P)

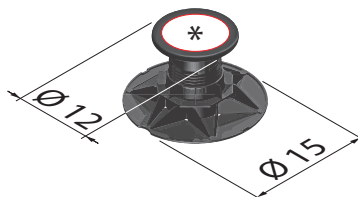

SM (P) (C)

CARICO MASSIMO  
MAXIMUM LOAD  
CHARGE MAXIMALE  
MAXIMALLAST  
KG. 400

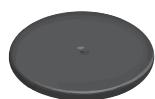

TO (P)

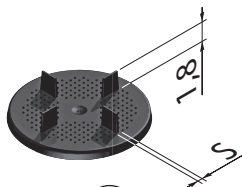

SP (C)

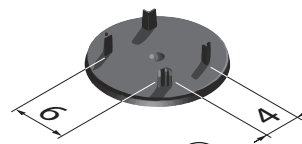

TM (C)

VISTA LATERALE / LATERAL VIEW / VUE LATÉRALE / SEITENANSICHT

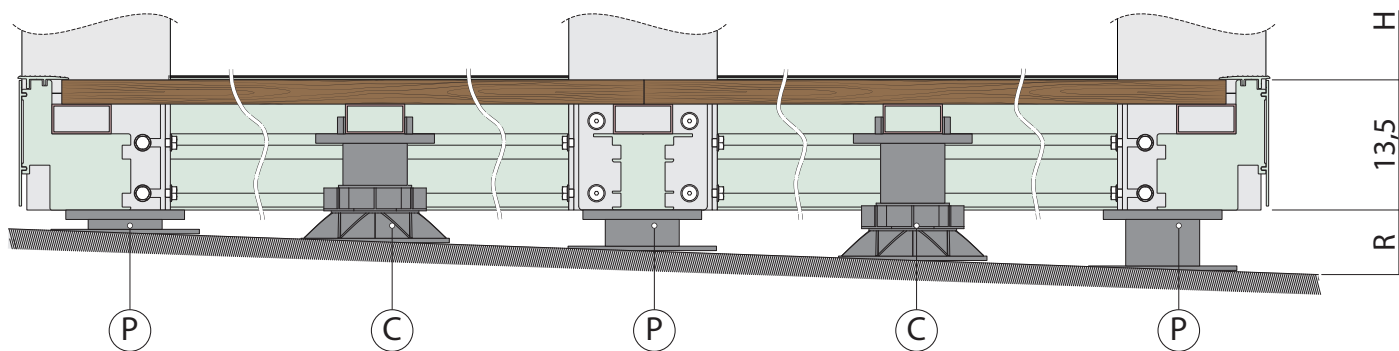

VISTA IN PIANTA / TOP VIEW / VUE DU DESSUS / DRAUFSICHT

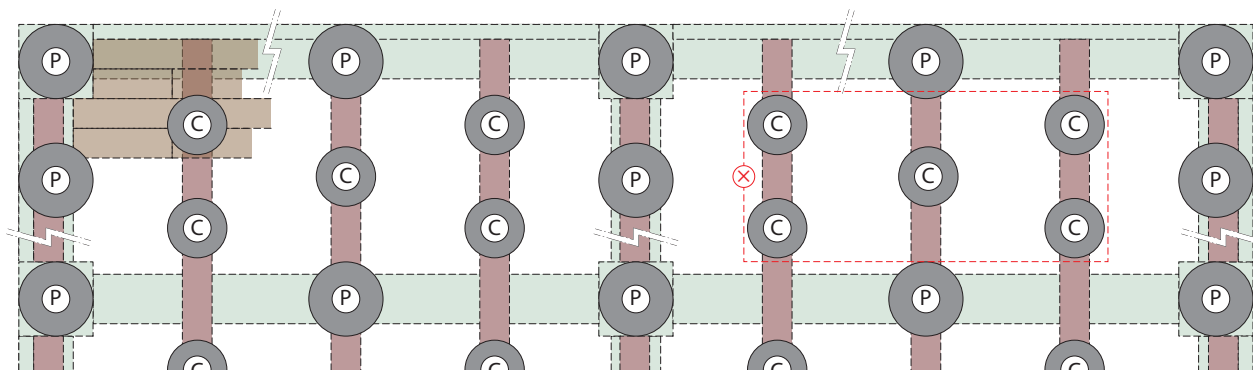

⊗ Esempio di disposizione quinconce dei martinetti interni / Example of quincunx disposition of the inner jacks  
Exemple de disposition quinconce des vérins internes / Beispiel einer Quincunx Anordnung der inneren Winden

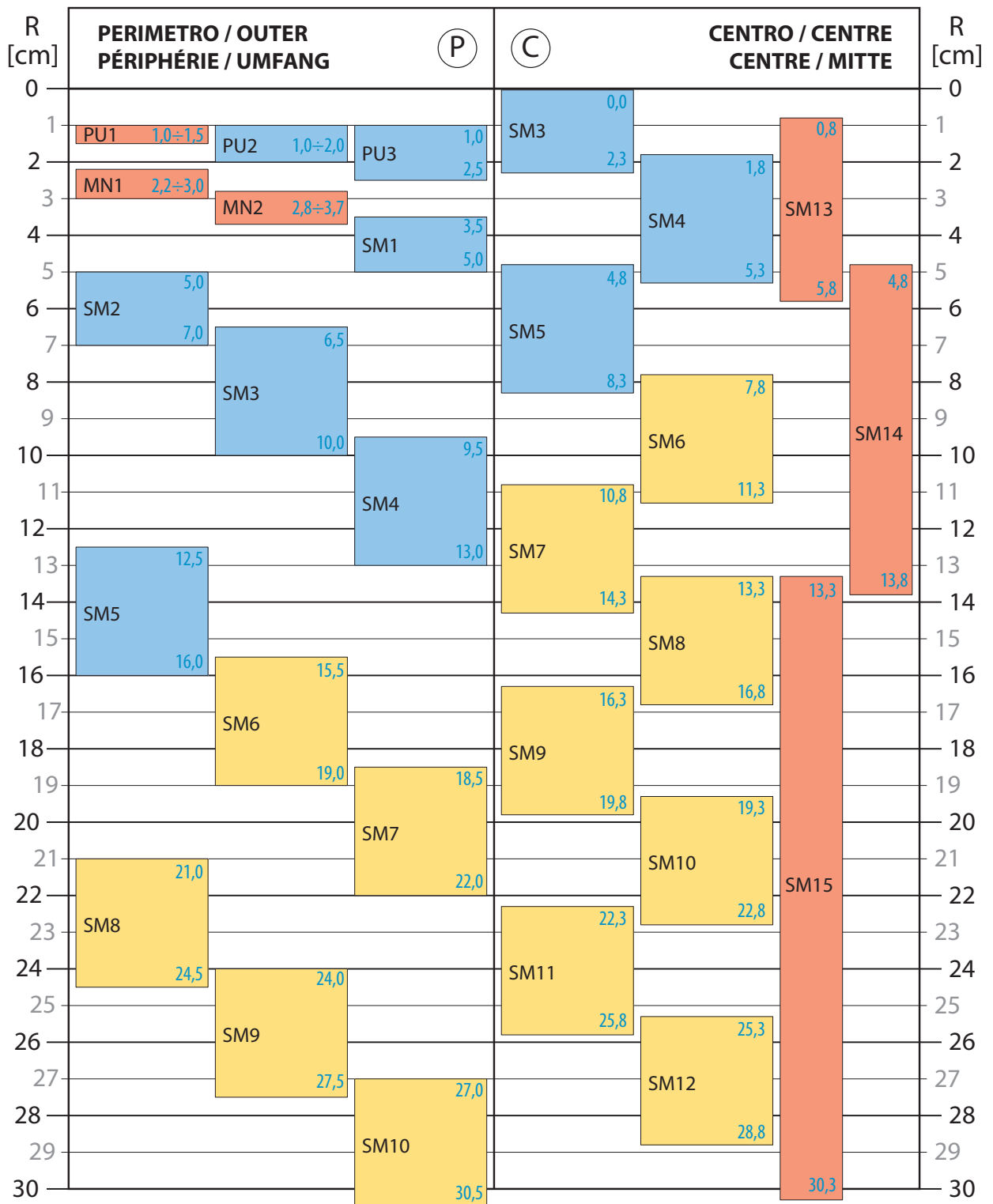

**R =** Dislivello da compensare  
 Difference in height  
 Différence de niveau à compenser  
 Auszugleichender Höhenunterschied

Su ordinazione (2-3 settimane)  
 On request (2-3 weeks)  
 Sur commande (2-3 semaines)  
 Auf Bestellung (2-3 Wochen)

Disponibili a magazzino  
 Available in stock  
 Disponibles en stock  
 Auf Lager

Su ordinazione (2-3 settimane) e lotti di almeno 25 pz  
 On request (2-3 weeks) and batches of at least 25 pcs  
 Sur commande (2-3 semaines) et lots d'au moins 25 pc  
 Auf Bestellung (2-3 Wochen) und Partien von mindestens 25 Stück





## SET PROMOTION 350×450 - 350×310

Pavimentazioni Déco (Doghe Ultrashield Antique 2,3×13,8×220)

Flooring Déco (Boards Ultrashield Antique 2,3×13,8×220)

Revêtements de sol Déco (Planches Ultrashield Antique 2,3×13,8×220)

Bodenbeläge Déco (Bretter Ultrashield Antique 2,3×13,8×220)

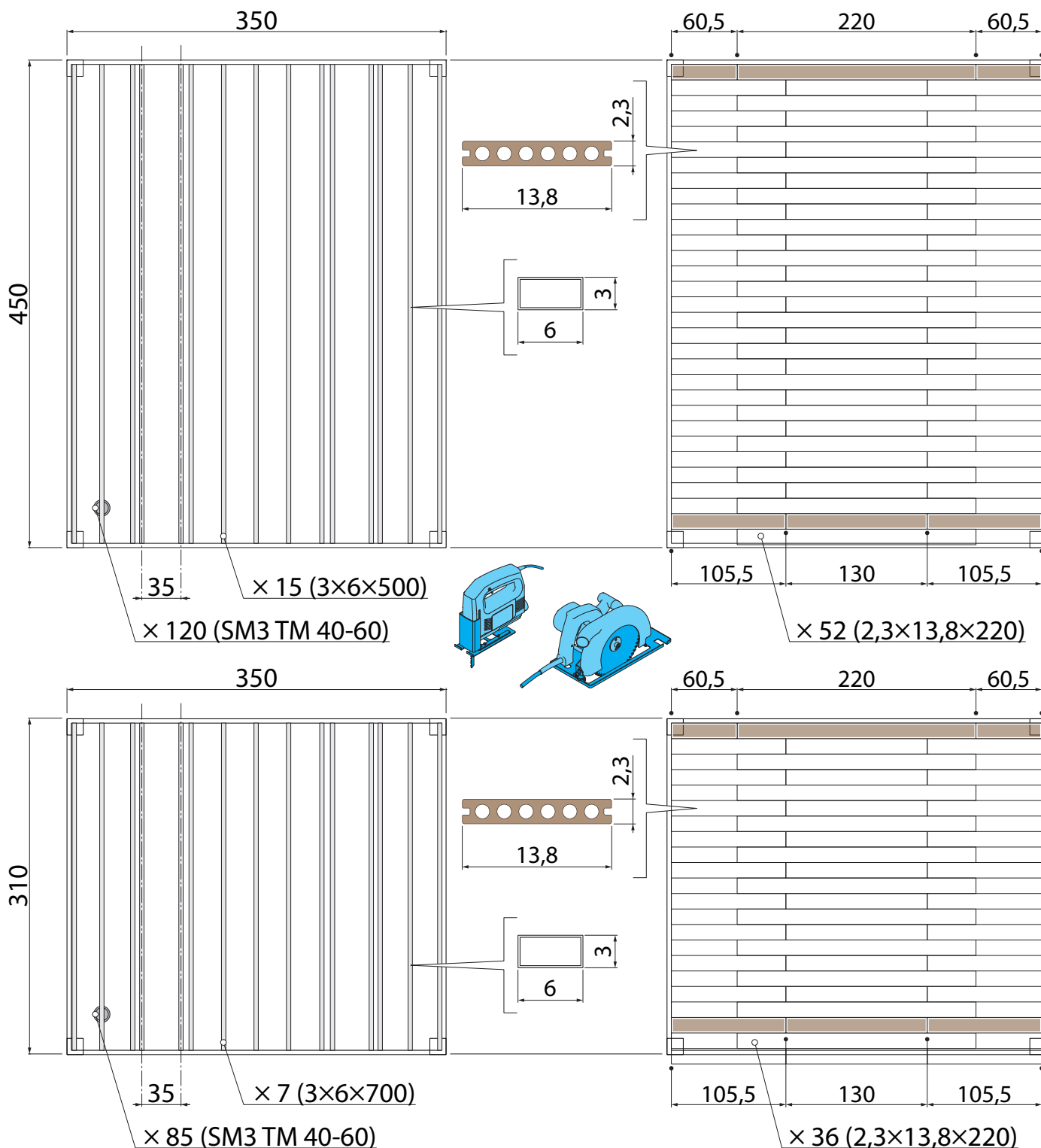

È possibile scaricare dal nostro portale B2B la documentazione del fornitore della pavimentazione.  
You can download the documentation of flooring supplier from our B2B portal.  
On peut télécharger depuis notre portail B2B la documentation du fournisseur du revêtement.  
Sie können das Lieferantehandbuch des Fußbodens von unserem B2B Portal herunterladen.

